

**THE PENCIL OF THE 4TH AND 3RD ORDER SURFACES
OBTAINED AS A HARMONIC EQUIVALENT OF THE PENCIL
OF QUADRICS THROUGH A 4TH ORDER SPACE CURVE OF
THE 1ST CATEGORY ***

UDC 514.144:530.12=111

Gordana Đukanović¹, Marija Obradović²

University of Belgrade,

¹The Faculty of Forestry, ²Faculty of Civil Engineering, Serbia
gordana.djukanovic@sfb.bg.ac.rs

Abstract. *This paper shows the process of inverting the 4th ordered space curve of the first category with a self-intersecting point (with two planes of symmetry) and determining its harmonic equivalent. There are harmonic equivalents for five groups of surfaces obtained through the 4th order space curve of the 1st category. Mapping was done through a system of circular cross-sections. Both classical and relativistic geometry interpretations are presented. We also designed spatial models – a spatial model of the pencil of quadrics and a spatial model of the pencil of equivalent quadrics. Besides the boundary surfaces, one surface of the 3rd order, which is an equivalent to a triaxial ellipsoid, passes through this pencil of surface of the 4th order. The center of inversion is located on the contour of the ellipsoid. The parabolic cylinder is mapped into its equivalent, by mapping the contour parabola of the cylinder, in the frontal projection, in relation to the center and the sphere of inversion into a contour curve of the 4th order surface. The generating lines of the parabolic cylinder, which are in a projecting position and pass through the antipode, are mapped into circles (also in a projecting position) whose diameters are from the center of inversion to the contour line. The application of the 4th order surfaces in architectural practice is also presented.*

Key words: *relativistic geometry, inversion, axial symmetry, pencil of the 4th and 3rd order surfaces.*

Received August 16, 2012

* **Acknowledgement.** The paper is a part of the research done within the project No. TP-37002, New bioecological materials for protection of soil and water, 2011-2014. and the project No. III 44006, The development of new information-communication technologies, using advanced mathematical methods with applications in medicine, energy, e-governance and the protection of national heritage.

1. INTRODUCTION

The 4th order space curve of the 1st category is obtained by intersecting two 2nd order surfaces and it defines the whole pencil of the 2nd order surfaces (just as the straight line obtained by intersecting planes defines the whole pencil of planes). Space curve is therefore called the fundamental curve of the pencil of quadrics or the "pencil line" of the pencil of quadrics.

There are four cones among the quadrics of the pencil, three of which can be cylinders as well. There are always two real cones, which means that the space curve can be obtained by intersecting two parabolic quadrics, cones or cylinders, i.e. by intersecting the simplest surfaces of the 2nd order [3].

The joint polar plane cuts the pencil of quadrics along the pencil of their contour conics (for the course of projection from the pole associated to the given plane). This pencil of conics is defined by four points in which the plane cuts the 4th order space curve of the 1st category. Three pairs of opposite sides of a complete quadrangle (defined by the same four points) are the contour generatrices of the three cones. The top of the fourth cone is in the associated pole – the fourth vertex of the tetrahedron. In its implicit form, the pencil of surfaces which passes through the intersection 4th order curve of the first category, obtained by the intersection of the two given surfaces, is determined by the following equations:

$$F_1(x, y, z) = 0 \text{ and } F_2(x, y, z) = 0$$

and are written as follows: $F_1(x, y, z) + \lambda \cdot F_2(x, y, z) = 0$.

The 4th order curve of the 1st category itself is obtained by the intersection of surfaces (F_1 and F_2), so it is determined by both the equations:

$$F_1(x, y, z) = 0 \text{ and } F_2(x, y, z) = 0.$$

If we eliminate one of the coordinates, we obtain a projection on the appropriate projection plane. [9]

2. THE 4TH ORDER SPACE CURVE OF THE 1ST CATEGORY WITH A SELF-INTERSECTING POINT (WITH TWO PLANES OF SYMMETRY) AND ITS HARMONIC EQUIVALENT

This section examines the harmonic equivalent of the pencil of quadrics presented in Fig. 1. There are harmonic equivalents for four groups of surfaces. We have also designed their spatial models, as well as a 3D spatial model of the pencil of quadrics and the pencil of equivalent quadrics.

When the pole of the pencil of quadrics' autopolar tetrahedron stands at a fictive (infinitely distant) point of space, its polar plane is a joint symmetry plane of the pencil of quadrics, on which the 4th order space curve of the 1st category (projected from a fictional pole, i.e. with the generatrices of the cylinder being its bisecant lines) is twice coincided with a conic.

There are seven types and possible arrangements of the four fundamental points of the pencil of conics (in the joint polar plane). Let's take a look at the space curve which passes through two coincided (1=2) and two separate fundamental points (3 and 4), as

presented in Fig. 1. There is an infinite number of quadrics passing through this 4th order curve of the first category, two of which are real and coincided cones (double cone $V_1=V_2$), and the other two (V_3 and V_4) are real and separate. The joint autopolar tetrahedron is degenerated into a joint tangential plane of the quadrics. The space curve has its self-intersecting double point in the vertex of the cone $V_1=V_2$ (first order tangents).

There is a great number of quadrics passing through the 4th order space curve of the 1st category. In this case, which is shown in Fig. 1, one quadric has been singled out from each group of quadrics (depending on the position of the axis of quadrics of z course) and their contours are shown in a joint symmetry plane. The arrows are used to mark boundaries within which, by selecting a vertical axis, we obtain a corresponding quadric. Each pencil of quadrics includes:

- 1) a parabolic cylinder (axis of x course) PC
- 2) an infinite number of revolving hyperboloids of one sheet (axis of z course, $\varphi > \varphi_k$) JRH
- 3) a twofold revolving cone (axis of z course) RK
- 4) an infinite number of revolving hyperboloids (z axis course, $\varphi > \varphi_k$) JRH
- 5) a revolving cylinder (axis of z course) RC
- 6) an infinite number of elongated revolving ellipsoids (axis of z course) IRE
- 7) a sphere L
- 8) an infinite number of flat revolving ellipsoids (axis of z course) SRE.

The division is taken from a master thesis - Djukanovic (Vasiljevic) G., 2000. [8]

In this pencil of quadrics, bold lines were used to draw a sphere and a revolving cylinder, with an axis of z course and one tangent point, through the 4th order space curve of the 1st category (Fig. 1). In Monge's projections, the 2nd order surfaces are presented with their contours, which are either straight lines or conics. By harmonic symmetry of contour surface elements, we obtain harmonically equivalent elements, which are contours of the 3rd and 4th order surfaces [17].

According to the basic principles of relativistic geometry, a straight line is equivalent to a circle, a plane to a sphere, conics are equivalent to the 4th or 3rd order curves in a 'plane', and quadrics are equivalent to the corresponding 3rd and 4th order surfaces. Fig. 2 shows a pencil of quadrics through the 4th order space curve of the 1st category and its harmonic equivalent – a pencil of the 4th and the 3rd order surface. The 4th order space curve of the 1st category (c_1), which is marked violet (Fig. 2 to the left) is mapped into a harmonically equivalent curve c_1 , which is also marked violet (Fig. 2 to the right). Due to the complexity of the construction procedure itself, the process of generating the equivalent surface will be explained separately for each quadrics. [4]

The revolving cone is inverted into a surface of the 4th order with a circular axis and circular generatrices which intersect twice (in $\bar{1}=\bar{2}$ and at \mathcal{S}). The circles that are in horizontal planes, perpendicular to the circular axis of the revolving quadric, are mapped into circles that are equivalent quadrics to the planes perpendicular to the circular axis. The cone is determined by a circle in H-plane (β) and vertex V_1 . Spatial harmonic symmetry of the cone is performed by using sphere - s and center of harmonic symmetry \mathcal{S} . When mapping by inversion, we use two straight lines (d_1 and d_2 , the contour lines of the cone in the frontal symmetry plane), the axis a which is located in F-plane and circles in H-plane (β).

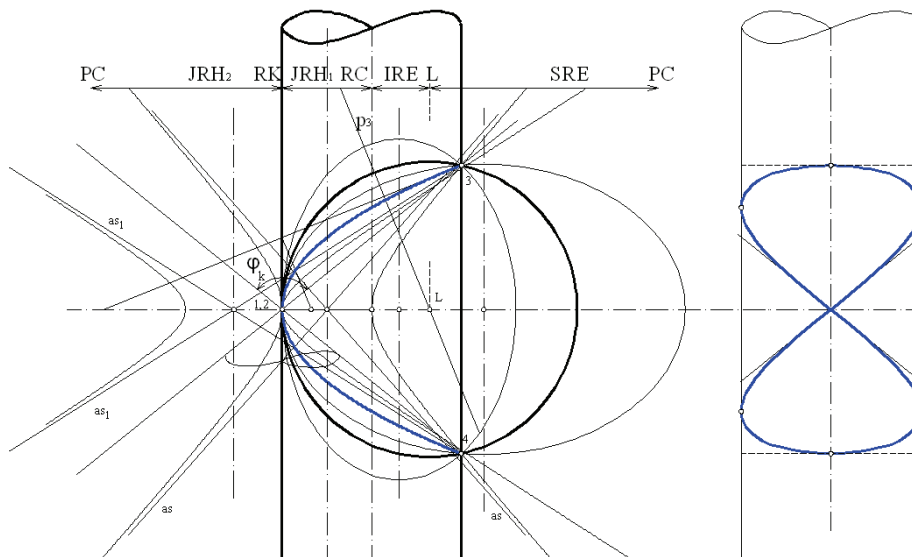

Fig. 1. Pencil of quadrics through the 4th order space curve of the 1st category

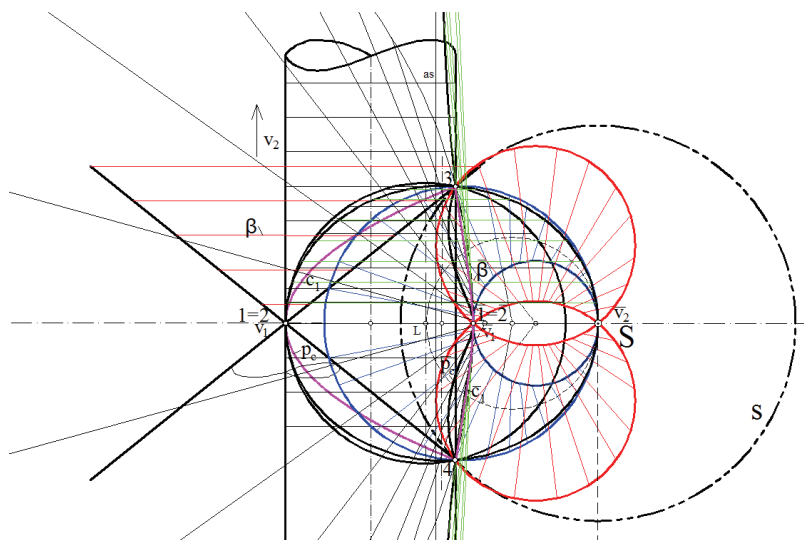

Fig. 1. The pencil of quadrics through the 4th order space curve of the 1st category and its equivalent pencil of surface of the 4th and 3rd order

In Fig. 3, the cone from the pencil of quadrics is mapped into a surface of the 4th order. The revolving cone has a system of circles in H planes (marked red and set in the projecting position, for example β), which is mapped into a system of the 4th order surfaces' circles (marked red as β , set in the projecting position and seen as straight lines concurrent at one point (K), which is marked on the axis of symmetry). Two straight lines that are contour generatrices (d_1 and d_2) of the cone are mapped into two circles (d_1 and d_2), which pass through the point $V_2 = S$ and through the mapped fundamental point of the pencil of conics V_1 . Vertex of the cone V_1 , located on the circle of harmonic symmetry, is mapped into the associated vertex of the surface V_1 . The axes of the cone a (z course) and c (axis c in the frontal symmetry plane is in the projecting position because of its y course) are mapped into circular axes passing through the points S and V_1 , while linear axis of symmetry b as a ray of symmetry maps into itself [5].

2.1. Individual quadrics from the pencil through the 4th order space curve of the 1st category and their harmonic equivalents

In this section, we have selected five surfaces from the pencil of quadrics through the 4th order space curve of the 1st category. They are shown in Fig. 2, as well as their mapping into surfaces of the 4th and 3rd order.

Firstly, the cone is mapped (Fig. 2). It is a revolving cone and its contour generatrices pass through the pencil of conics' fundamental points in the symmetry plane of all conics ($V_1=V_2$). In relativistic geometry, cone has two vertices, one of which is necessarily in the antipode (S). The cone contours are two "straight lines", and since the straight line is equivalent to the circle, the contours of the equivalent surfaces in the harmonic group of cones, depending on the position (S, s), will be two circles, a circle and a "straight line" or two "straight lines". The equivalents of these contour generatrices of the cone intersect at two vertices of the surface of the 4th, 3rd or 2nd order ("order" in the classical sense) [6].

The revolving cone is inverted into a surface of the 4th order with a circular axis and generatrices that intersect twice (in $l=2$ and at S). The circles that are in horizontal planes perpendicular to the axis of revolving quadric, are mapped into circles in the planes perpendicular to the circular axis of equivalent quadric. The cone is determined by the circle in H-plane (β) and vertex V_1 . Spatial harmonic symmetry of cone is performed by using sphere- s and the center of harmonic symmetry S . When mapping by inversion, we use two straight lines (d_1 and d_2 , the contour lines of the cone in the frontal plane of symmetry), the axis a which is located in F-plane, and circles in H-plane (β). In Fig. 3, the cone from the pencil of quadrics is mapped into a surface of the 4th order.

The revolving cone has a system of circles in H planes (coloured red and set in the projecting position, marked by β), which is mapped into a system of circles of the 4th order surfaces (coloured red and marked by β), set in the projecting position and seen as straight lines concurrent at one point (K), which is denoted on the axis of symmetry). Two straight lines that are contour generatrices (d_1 and d_2) of the cone are mapped into two circles (d_1 and d_2), which pass through the point $V_2 = S$ and through the mapped fundamental point of the pencil of conics V_1 . Vertex of the cone V_1 , which is located on the circle of harmonic symmetry, is mapped into the associated vertex of the surface V_1 . The axes of the cone a (z course) and c (the axis c in the frontal symmetry plane is in the projecting position because

of its y course) are mapped into circular axes passing through points S and \bar{V}_1 , while linear axis of symmetry b , as a ray of symmetry, maps into itself [14].

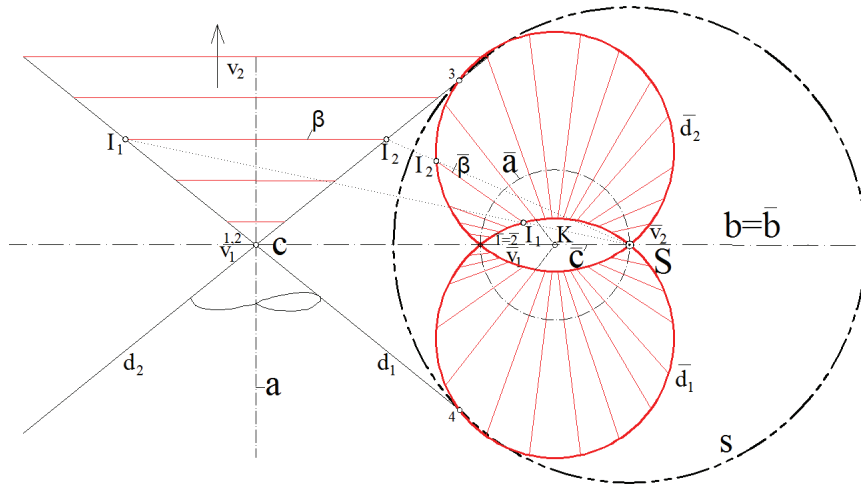

Fig. 3. Cone and its harmonic equivalent – a surface of the 4th order

Based on the aforesaid, we can conclude that the 4th order surface obtained by harmonic symmetry of the cone ($n=2, 2 \times n=4$) will have circles in mutually perpendicular planes as its generatrix and directrix, one linear and two circular axes of harmonic symmetry, and two singular points.

Fig. 4 shows a spatial model of the cone and harmonically equivalent surfaces of the 4th order (spindle-shaped cyclide) which was performed by using two systems of circular cross-section [10].

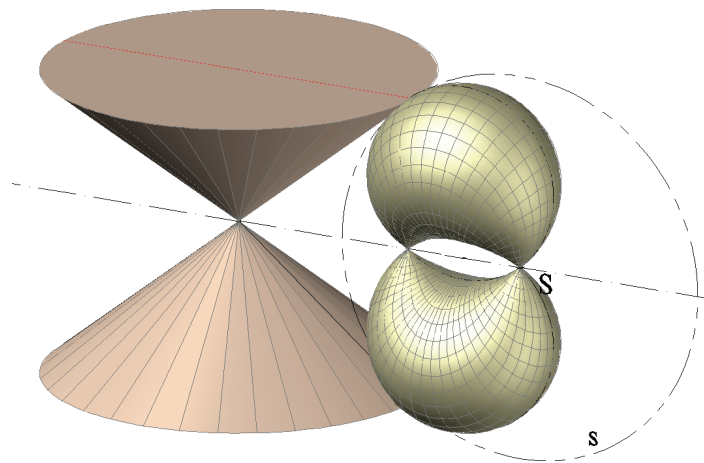

Fig. 4. Cone and its harmonic equivalent – spindle-shaped cyclide (3D model)

When two vertices of the cone coincide in the antipode, a cylinder is obtained. Fig. 5 shows a revolving cylinder and its harmonic equivalent – a cyclide of Dupin. The generatrix of the cylinder is mapped, by harmonic symmetry, into a straight line or a circle. Two generatrices, located in the same plane, are mapped into two circles whose intersection angle is zero. All generatrices of the harmonically inverted surface will have one point of tangency - a singular, self-tangent point (\mathcal{S}).

The revolving cylinder (Fig. 5) is inverted into the 4th order surface with a circular axis and generatrices that touch at \mathcal{S} . Mapping of contour generatrices (i_1 and i_2) is carried out in F – plane. They map into two circles that touch at a singular point \mathcal{S} (the self-intersection angle is zero). Each generatrix of the revolving cylinder forms a new plane with a center of harmonic symmetry. Two generatrices are mapped in each plane. The result of the inversion are circles that pass through the singular point (\mathcal{S}) and form the first system of circular sections of the 4th order surfaces (as shown in the 3D presentation).

Mapping of the circular sections of cylinder, which are perpendicular to axis a , is performed in the same manner as with the revolving cone. Thus, we obtain circular sections of the inverted surface which are perpendicular to F -plane (in the projecting position) and a circular axis a of this surface.

Fig. 6 shows a spatial model of the 4th order surface, called Dupin cyclide, which is a harmonic equivalent of cylinder. Modeling is similar to the modeling of spindle-shaped cyclide. It is performed using AutoCAD software package, using two systems of circular sections.

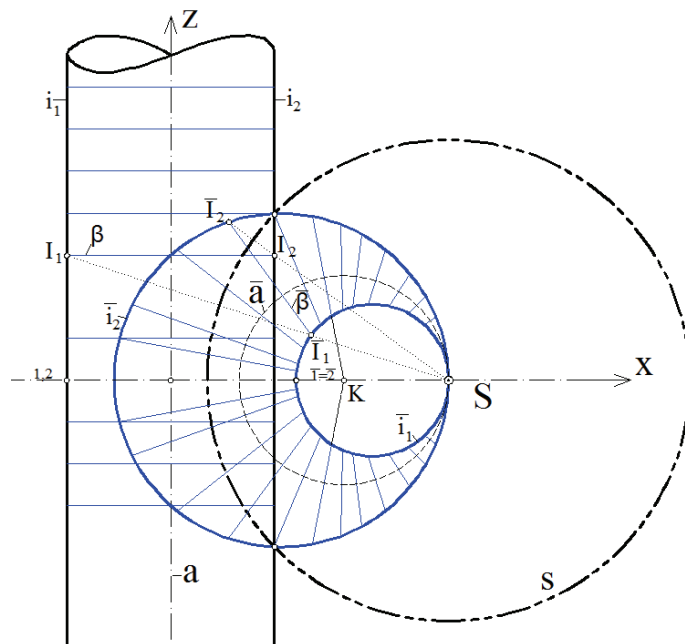

Fig. 5. Harmonic equivalent of cylinder - Dupin cyclide

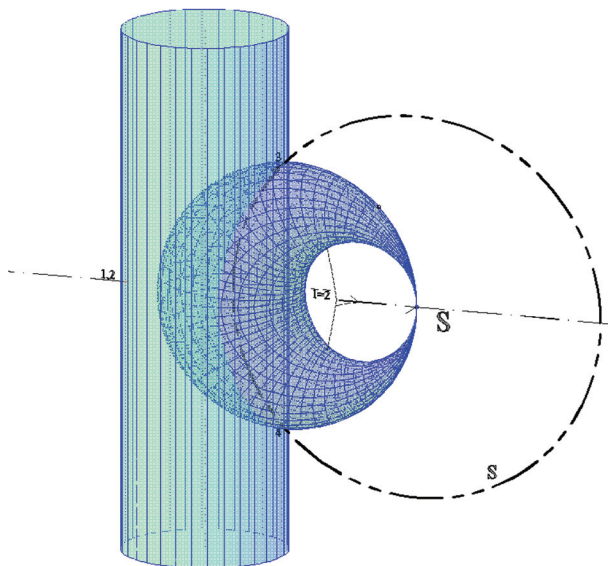

Fig. 6. Cylinder and Dupin cyclide – 3D model

It is known that the harmonic equivalent of a sphere is also a sphere. this is shown in Fig. 7. We can notice that the circle of the sphere, β , maps into the circle $\bar{\beta}$ of the mapped sphere.

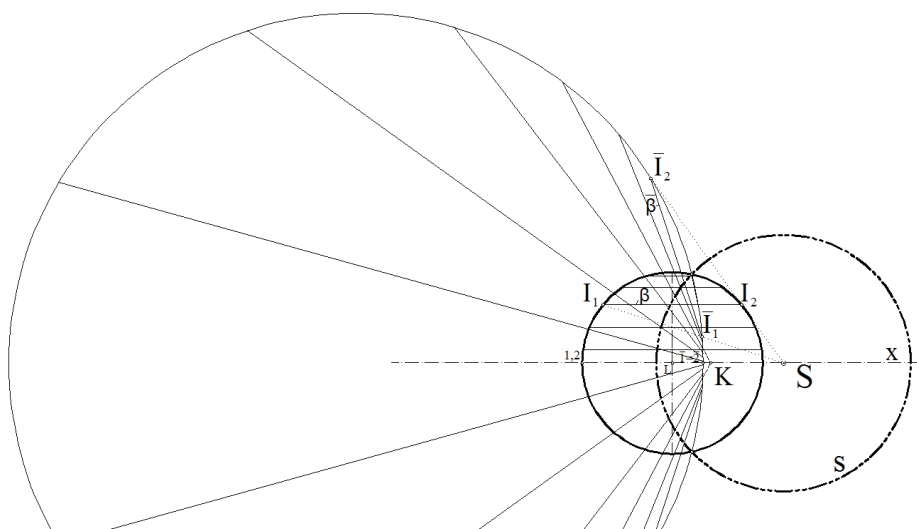

Fig. 7. Sphere and its harmonic equivalent – also a sphere

Besides the boundary surfaces, another 3rd order surface passes through the defined pencil of the 4th order surface. It is equivalent to a three-axial ellipsoid and is shown in Fig. 8.

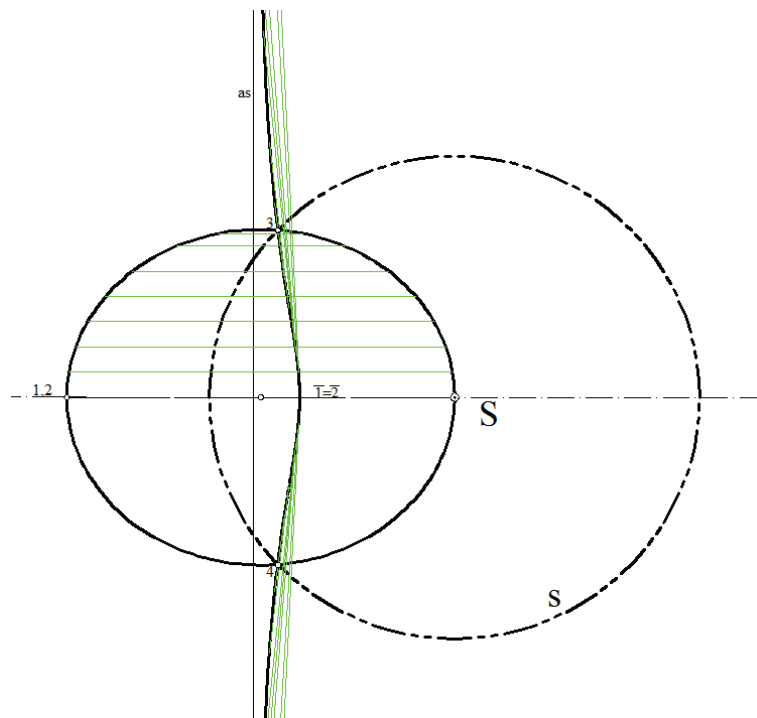

Fig. 8. Revolving ellipsoid and its harmonic equivalent – a 3rd order surface

Since the center of inversion is in the vertex of the contour ellipse in the joint symmetry plane, it is mapped into a 3rd order curve whose asymptote is marked by 'as' in Fig. 8. The osculatory circle is at the point S of the ellipse mapped into the asymptote.

In Fig 9, a pencil of conics and its harmonically equivalent pencil of the 4th order surface are shown. The curve that is equivalent to the space 4th order curve of the 1st category is coloured purple.

The parabolic cylinder is mapped into its equivalent, i.e. the contour parabola of cylinder is mapped by using the center and the sphere of inversion (S, s) into a contour curve of the 4th order surface. The generatrices of the parabolic cylinder, which are in a projecting position, pass through the antipode and map into circles (also in a projecting position) with diameters that stretch from the point S to the contour curve of the 4th order surface for the second projection [2].

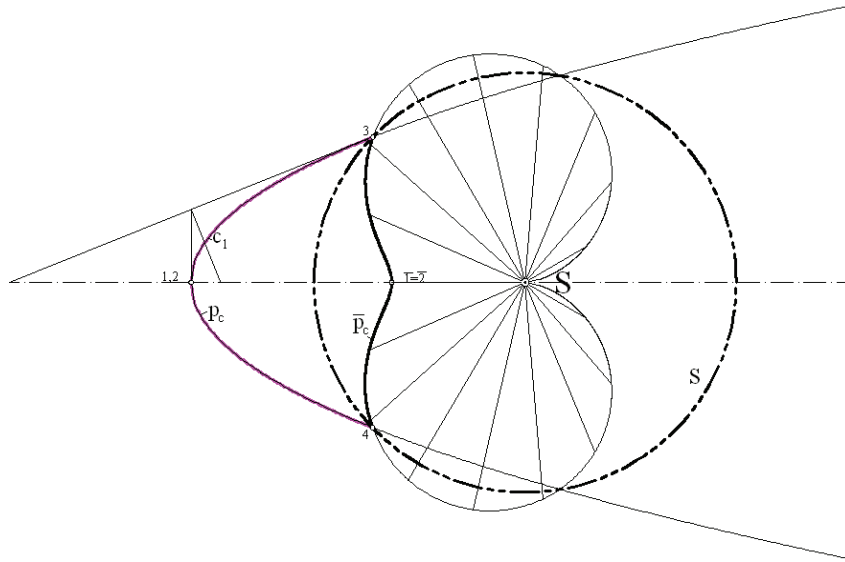

Fig. 9. Parabolic cylinder and its harmonic equivalent – a 4th order surface with a cusp

Besides the equivalent pencil of revolving quadrics, another pencil of equivalent quadrics passes through the c_1 curve (Fig. 10 A pencil of conics and its harmonically equivalent pencil of the 4th order surface - a 3D model). They are harmonically equivalent to all the quadrics of the pencil through the 4th order space curve of the 1st category.

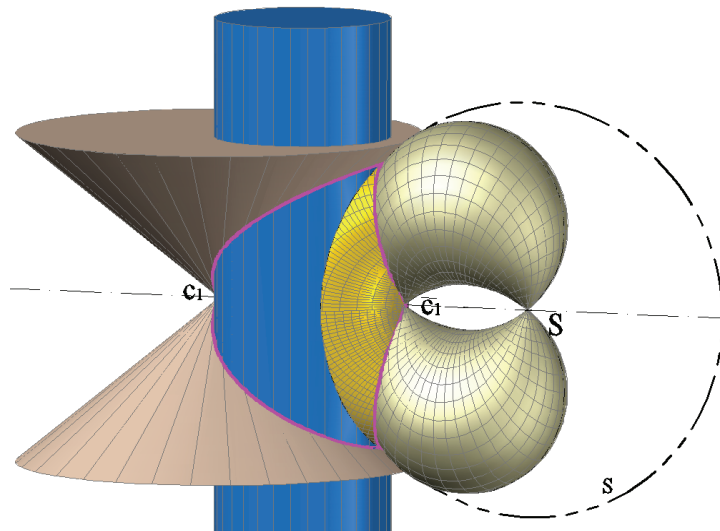

Fig. 10. A pencil of conics and its harmonically equivalent pencil of the 4th order surface - a 3D model

All spheres in space can be spheres of inversion for the 4th order curve of the 1st category and its harmonically equivalent curve. A unique pencil of quadrics passes through any of these 4th order space curves, while multitude (∞^3) pencils of the 4th order surfaces pass through the equivalent curve, since any sphere can be a sphere of inversion. These pencils correspond to all the rest of possible pencils of quadrics which are different from the unique one [7].

3. CREATING OBJECTS MODELED BY GEOMETRY OF THE 3RD AND 4TH ORDER CURVES AND SURFACES

There is an unbreakable link between architecture, nature and science. Knowledge of analytic geometry and its application to natural forms in architecture allows us to create buildings that are not only attractive in appearance, but also have significant qualities in terms of strength, stiffness and stability. With the advancement of parameter-based building design, an array of interesting and inspiring buildings has appeared all around the world. They prove the strong connection between geometry and architecture [11].

Let's look at one example of the above, Crescent Moon Tower project in Dubai, as shown in Fig. 11. The photo was taken from a paper Shambina S. et al., 2012 [16]. We can notice that the geometric shape of this building, which proves that even extremely bold forms are feasible nowadays, looks like a cyclide.

Fig. 12 shows a surface modeled in AutoCAD, obtained by harmonic symmetry of a revolving paraboloid which is very similar to the above-mentioned project: it is crescent-shaped and has two systems of circular cross-sections. [15]



Fig. 11. Crescent Moon Tower project in Dubai

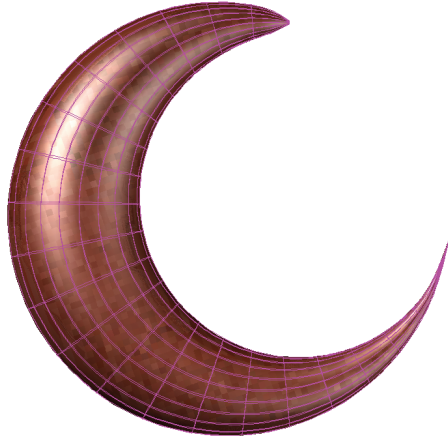

Fig. 12. A 4th order surface obtained as a harmonic equivalent of a revolving paraboloid

the projecting position, and concurrent at the point K . Mapping by inversion uses the contour line of the paraboloid in the frontal symmetry plane, axis a in F-plane and circles in H-planes (β). The axis of cone (z course) is mapped into a circular axis that passes through the point S .

The revolving paraboloid, with the axis of z course, is inverted into a 4th order surface with a circular axis and circular generatrices. It is shown in Fig 13. Spatial harmonic symmetry of the paraboloid is carried out by using sphere- s and center of harmonic symmetry S . The circles that are in horizontal planes, perpendicular to the circular axis of the revolving quadric (coloured blue, in the projection position and marked by β), map into circles ($\bar{\beta}$) in the planes perpendicular to the circular axis of the equivalent quadric. In the projection on the frontal symmetry plane, they are in the

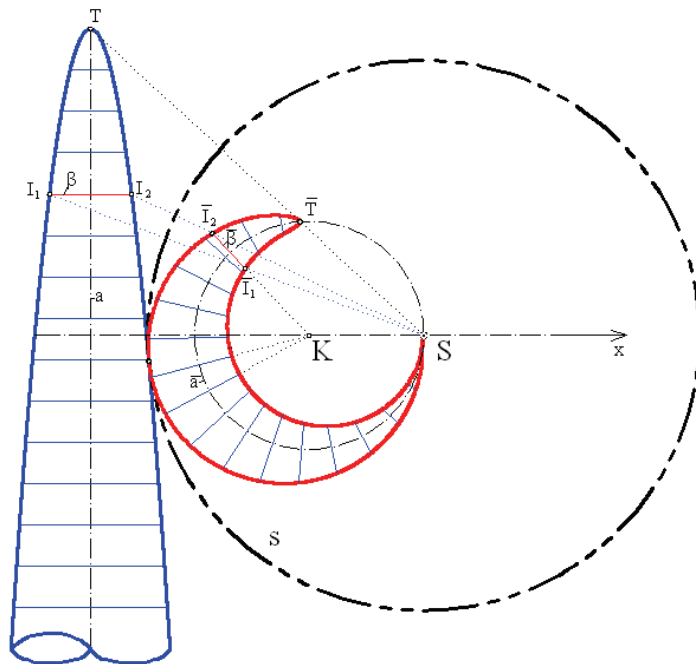

Fig. 13. Mapping of a revolving paraboloid into a crescent-shaped surface of the 4th order

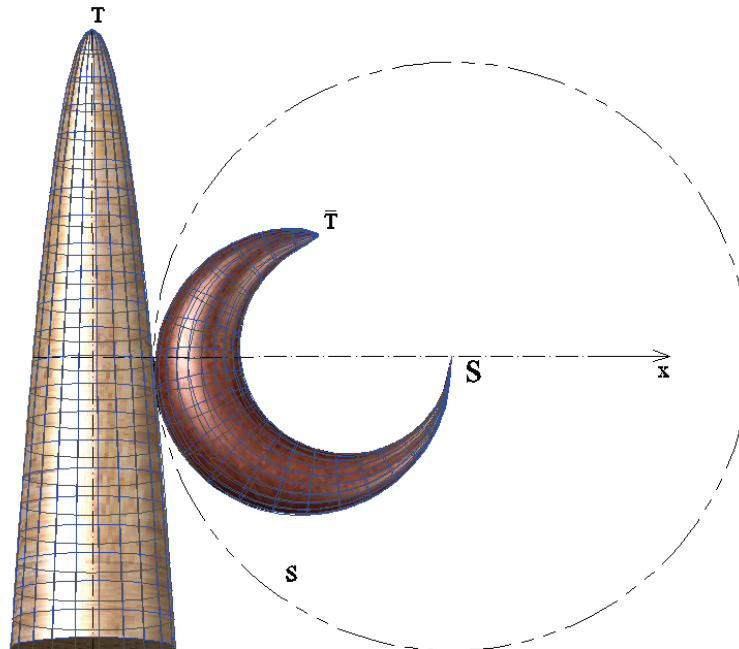

Fig. 14. Spatial model of a revolving paraboloid and an inverted crescent-shaped surface of the 4th order

When we talk about the application of various geometric surfaces in architecture, it is necessary to mention diagrid system, which has proved to be the most optimal new structural design system for performing free, parametrically-designed forms. This structural design system consists of a diagonal grid of carriers, which acts as an exoskeleton, and as such it can "wrap" the most diverse geometric forms obtained by harmonic symmetry or in any other way [12].

Diagrid is a structural system which has been widely used for the construction of modern high-rise buildings made of steel [13]. It consists of triangular structures with diagonal beam support. This system has excellent structural efficiency and aesthetic potential provided by the unique geometric configuration of the system. It uses a unit that can be used over and over again making a grid which can give rise to a myriad of structural forms. Diagrid can be used for a variety of geometric shapes and it provides enormous potential for the future of architecture. There is an increasing number of tall buildings worldwide [1], which dominate the whole landscape around them.

Forms, such as geometric surfaces of 3rd and 4th order, can easily be performed in diagrid system, especially because we can mathematically determine the courses of isolines, providing the optimal supporting ribs disposition, for ideal load distribution.

4. CONCLUSION

By using different spheres and centers of harmonic symmetry S , surfaces of lower orders can be, by harmonic symmetry, transformed into surfaces of higher orders that have attractive shapes and are suitable for construction due to the system of circular sections obtained by using the above-described mapping. For the construction of buildings modeled in this way, for example in digrid system, it would be necessary to find the optimal directions of isolines, which will be the directions of the supporting ribs in the diagrid structural system, and thus make its loading capacity optimal. Future research in this area should go in this direction

REFERENCES

1. Ali M. M. and Moon K., "Structural Developments in Tall Buildings: Currents Trends and Future Prospects", *Architectural Science Review*, 50.3, 2007, pp 205-223.
2. Brieskorn E., Knäorrer H., "Plane Algebraic Curves", Birkhäuser Verlag, Basel-Boston-Stuttgart, 1986.
3. Dovniković L., "Nacrtno-geometrijska obrada i klasifikacija ravnih krivih III reda", doktorski rad, Arhitektonski fakultet, Beograd, 1977.
4. Dovniković L., "The Relativistic Geometry of Harmonic Equivalents", Proc. 6th ICECGDG, Tokyo, 1994, pp 305-309.
5. Dovniković L., "Hamonija sfera - Relativistička geometrija harmonijskih ekvivalenata", Matica srpska, Novi Sad, 1999.
6. Dovniković L., "The Relativistic Geometry as the Legendary 'Royal Road' to the Whole of Geometry", Proc. 10th ICGG, Kiev, 2002, pp 152-161.
7. Dovniković L., "A Pencil of Quadrics and Multitude of Pencils of Quadrics Harmonic Equivalents through a Fourth Order Space Curve", *Mongeometrija*, predavanje po pozivu, Beograd, 2004.
8. Đukanović (Vasiljević) G., "Prostorna geneza pramenova konika", magistarski rad, Arhitektonski fakultet, Beograd, 2000.
9. Đukanović (Vasiljević) G., Maksić J., "Pencil of Conics as Different Plane Intersections of Pencil of Quadrics", Proceedings of 10th ICGG, 28 July - 2 August 2002, Kiev, Ukraine, 2002, pp (177-181).
10. Janić M., Đukanović G., Grujović D., "Modeling of a Divider in the Torrents", ICEGD 2011- "Sustainable Eco Design", IASI, Romania, THE 4TH International Conference on Engineering Graphics and Design, pp 263-270.
11. Krsić S., "Geometrijske površi u arhitekturi", monografija, Niš, Galaksija, Građevinsko – arhitektonski fakultet Univerzitet u Nišu, 2012.
12. Moon, K., Connor J. J. and Fernandez J. E., "Diagrid Structural Systems for Tall Buildings: Characteristics and Methodology for Preliminary Design", *The Structural Design of Tall and Special Buildings*, Vol. 16.2, 2007, pp 205-230.
13. Moon K., "Design and Construction of Steel Diagrid Structures", School of Architecture, Yale University, New Haven, USA, 2009.
14. Nikolić V., Krsić S., Nikolić O., "Cone Whose Directrix is a Cylindrical Helix and the Vertex of the Directrix is – a Cochleoid Cone", *FACTA UNIVERSITATIS, Series: Architecture and Civil Engineering* Vol. 9, No 3, 2011, pp. 501 - 509
15. Obradović M., Popkonstantinović B., Mišić S. and Petrović M., "Possibilities of Deltahedral Concave Cupola Form Application in Architecture", ICEGD 2011- "Sustainable Eco Design", IASI, Romania, The 4TH International Conference on Engineering Graphics and Design.
16. Shambina S., Sazonov K.: Application of analytic surfaces and bionic forms in architectural design, Proceedings of 3rd International Scientific Conference on *Mongeometrija* 2012., Novi Sad, 2012, pp 499-506.
17. Stavrić M., "Harmonijska sinteza i konstruktivna obrada površi viših redova", doktorska disertacija, Arhitektonski fakultet u Beogradu, 2002.

PRAMEN POVRŠI 4. I 3. REDA REDA DOBIJEN KAO HARMONIJSKI EKVIVALENT PRAMENA KVADRIKA KROZ PROSTORNU KRIVU 4. REDA 1. VRSTE

Gordana Đukanović, Marija Obradović

U radu je inverzijom preslikana prostorna kriva 4. reda prve vrste sa samopresečnom tačkom (sa dve ravni simetrije) i određen je njen harmonijski ekvivalent. Prikazani su harmonijski ekvivalenti za pet grupa površi koje su dobijene kroz prostornu krivu 4 reda 1 vrste. Preslikavanje je rađeno preko sistema kružnih preseka. Dato je klasično i tumačenje u relativističkoj geometriji. Takođe su urađeni i prostorni modeli - prostorni model pramena kvadrika i pramena ekvivalentnih kvadrika. Kroz ovaj pramen površi 4. reda, osim graničnih površi, prolazi i jedna površ 3. reda koja je ekvivalent troosnom elipsoidu. Centar inverzije nalazi se na konturi elipsoida. Parabolički cilindar se preslikava u svoj ekvivalent, tako što se konturna parabola cilindra, za drugu projekciju, preslika u odnosu na centar i sferu inverzije u konturnu krivu površi 4. reda. Izvodnice paraboličkog cilindra, koje su u projicirajućem položaju i prolaze kroz antipod, preslikavaju se u krugove (takođe u projicirajućem položaju) čiji su prečnici od centra inverzije do konturne linije. Prikazana je i primena površi 4. reda u arhitektonskoj praksi.

Ključne reči: *relativistička geometrija, inverzija, osna simetrija, pramen površi 3. i 4. reda.*